

PART NO.	"A"
REHCBS-4-01	1/4 [6.4]
REHCBS-5-01	5/16 [7.9]
REHCBS-8-01	1/2 [12.7]

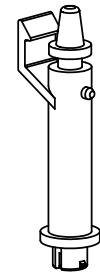
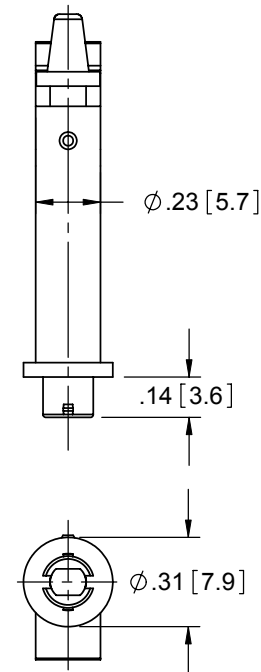
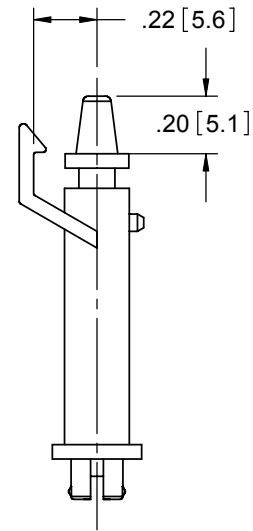
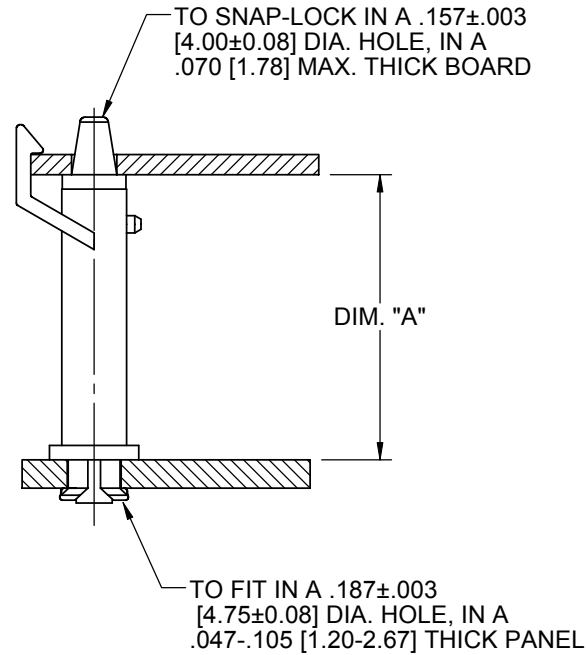

NOTES:
 1. MATERIAL: NYLON 6/6 (RMS-01)
 2. COLOR: NATURAL.

TITLE: RIVET EDGE HOLD CIRCUIT BOARD SUPPORT					DWG IN IN [MM]	
CREATED USING SOLIDWORKS	FILE #: REHCBS	DWN: SK	APP: -	FINAL		
TOLERANCES UNLESS NOTED .XX=±.010 .XXX=±.005 FRAC.=±1/64 ANG.=±1°	SHEET: 1 OF 1	SHEET SIZE: A	DT: 03/04/05	CHKD: -	PART #	PRINT TYPE
	RE: RICHCO, INC.	RICHCO, INC. ENG@RICHCO-INC.COM (773) 539-4060		SEE TABLE	CA	

REV.	DESCRIPTION	ENGR.	DATE
J	SEE CO 200041 FOR CHANGES	SK	09/28/07
I	SEE ECN #957 FOR CHANGES	SK	03/04/05
-	SEE ENGINEERING FOR REV. A-H	-	----